

DC336L 加长刃

硬质合金涂层钻头

CARBIDE COATED DRILL

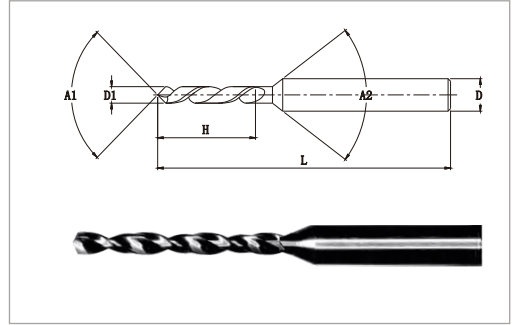

直径范围: $\Phi 0.04 - \Phi 3.0\text{mm}$

直径公差: $0 - 0.005\text{mm}$

- ◆ 采用超微细颗粒硬质合金圆棒
Ultra fine cemented carbide round bar was used.
- ◆ 超精公差管控, 优秀的切削力与排屑性
Ultra precision tolerance control, excellent cutting force and chip removal.
- ◆ 特别适用于工程塑胶、一般钢等软体材料精密的孔加工
Especially suitable for engineering plastics, general steel and other soft materials precision hole processing.
- ◆ DLC涂层增加润滑性, 增加排屑效果
DLC coating increases lubricity and chip removal effect.

可切削材料 (● 最适合 ● 适合)

碳素钢 S45C S55C	合金钢 SK·SCM SUS	预硬钢 NAK HPM	淬火钢 ~55HRC ~60HRC ~70HRC			高温 合金	铜合金	铝合金	树脂	工程 塑料
●	●	●				●	●	●	●	●
铸铁	钛合金	玻璃 纤维	电木	石墨	氧化锆	单晶硅	陶瓷	碳纤维		
●	●	●	●							

單位: (mm)

單位: (mm)

商品号 EDP NO.	直径 D1	刃长 H	柄径 D	全长 L
336L-00400	0.040	0.6	3	38
336L-00450	0.045	0.7	3	38
336L-00500	0.050	0.9	3	38
336L-00550	0.055	0.9	3	38
336L-00600	0.060	0.9	3	38
336L-00650	0.065	0.9	3	38
336L-00700	0.070	1.2	3	38
336L-00750	0.075	1.2	3	38
336L-00800	0.080	1.2	3	38
336L-00850	0.085	1.2	3	38
336L-00900	0.090	1.2	3	38
336L-00950	0.095	1.2	3	38
336L-01000	0.10	3.0	3	38
336L-0110	0.11	3.0	3	38
336L-0120	0.12	4.0	3	38
336L-0130	0.13	4.0	3	38
336L-0140	0.14	4.0	3	38
336L-0150	0.15	5.0	3	38
336L-0160	0.16	5.0	3	38
336L-0170	0.17	5.0	3	38
336L-0180	0.18	5.0	3	38
336L-0190	0.19	5.0	3	38
336L-0200	0.20	5.0	3	38
336L-0210	0.21	5.0	3	38
336L-0220	0.22	5.0	3	38
336L-0230	0.23	5.0	3	38
336L-0240	0.24	5.0	3	38
336L-0250	0.25	5.0	3	38
336L-0260	0.26	6.0	3	38
336L-0270	0.27	6.0	3	38
336L-0280	0.28	6.0	3	38
336L-0290	0.29	6.0	3	38
336L-0300	0.30	8.0	3	38
336L-0310	0.31	8.0	3	38
336L-0320	0.32	8.0	3	38
336L-0330	0.33	8.0	3	38
336L-0340	0.34	8.0	3	38
336L-0350	0.35	8.0	3	38
336L-0360	0.36	8.0	3	38
336L-0370	0.37	8.0	3	38
336L-0380	0.38	8.0	3	38
336L-0390	0.39	8.0	3	38
336L-0400	0.40	9.0	3	38
336L-0410	0.41	9.0	3	38
336L-0420	0.42	9.0	3	38
336L-0430	0.43	9.0	3	38
336L-0440	0.44	9.0	3	38
336L-0450	0.45	9.0	3	38
336L-0460	0.46	9.0	3	38
336L-0470	0.47	9.0	3	38
336L-0480	0.48	9.0	3	38

商品号 EDP NO.	直径 D1	刃长 H	柄径 D	全长 L
336L-0490	0.49	9.0	3	38
336L-0500	0.50	9.0	3	38
336L-0510	0.51	9.0	3	38
336L-0520	0.52	9.0	3	38
336L-0530	0.53	9.0	3	38
336L-0540	0.54	9.0	3	38
336L-0550	0.55	9.0	3	38
336L-0560	0.56	9.0	3	38
336L-0570	0.57	9.0	3	38
336L-0580	0.58	9.0	3	38
336L-0590	0.59	9.0	3	38
336L-0600	0.60	10.0	3	38
336L-0610	0.61	10.0	3	38
336L-0620	0.62	10.0	3	38
336L-0630	0.63	10.0	3	38
336L-0640	0.64	10.0	3	38
336L-0650	0.65	10.0	3	38
336L-0660	0.66	10.0	3	38
336L-0670	0.67	10.0	3	38
336L-0680	0.68	10.0	3	38
336L-0690	0.69	10.0	3	38
336L-0700	0.70	10.0	3	38
336L-0710	0.71	10.0	3	38
336L-0720	0.72	10.0	3	38
336L-0730	0.73	10.0	3	38
336L-0740	0.74	10.0	3	38
336L-0750	0.75	10.0	3	38
336L-0760	0.76	10.0	3	38
336L-0770	0.77	10.0	3	38
336L-0780	0.78	10.0	3	38
336L-0790	0.79	10.0	3	38
336L-0800	0.80	10.0	3	38
336L-0810	0.81	10.0	3	38
336L-0820	0.82	10.0	3	38
336L-0830	0.83	10.0	3	38
336L-0840	0.84	10.0	3	38
336L-0850	0.85	10.0	3	38
336L-0860	0.86	10.0	3	38
336L-0870	0.87	10.0	3	38
336L-0880	0.88	10.0	3	38
336L-0890	0.89	10.0	3	38
336L-0900	0.90	12.0	3	38
336L-0910	0.91	12.0	3	38
336L-0920	0.92	12.0	3	38
336L-0930	0.93	12.0	3	38
336L-0940	0.94	12.0	3	38
336L-0950	0.95	12.0	3	38
336L-0960	0.96	12.0	3	38
336L-0970	0.97	12.0	3	38
336L-0980	0.98	12.0	3	38
336L-0990	0.99	12.0	3	38

單位: (mm)

商品号 EDP NO.	直径 D1	刃长 H	柄径 D	全长 L
336L-1000	1.00	12.0	3	38
336L-1010	1.01	12.0	3	38
336L-1020	1.02	12.0	3	38
336L-1030	1.03	12.0	3	38
336L-1040	1.04	12.0	3	38
336L-1050	1.05	12.0	3	38
336L-1060	1.06	12.0	3	38
336L-1070	1.07	12.0	3	38
336L-1080	1.08	12.0	3	38
336L-1090	1.09	12.0	3	38
336L-1100	1.10	12.0	3	38
336L-1110	1.11	12.0	3	38
336L-1120	1.12	12.0	3	38
336L-1130	1.13	12.0	3	38
336L-1140	1.14	12.0	3	38
336L-1150	1.15	12.0	3	38
336L-1160	1.16	12.0	3	38
336L-1170	1.17	12.0	3	38
336L-1180	1.18	12.0	3	38
336L-1190	1.19	12.0	3	38
336L-1200	1.20	18.0	3	50
336L-1210	1.21	18.0	3	50
336L-1220	1.22	18.0	3	50
336L-1230	1.23	18.0	3	50
336L-1240	1.24	18.0	3	50
336L-1250	1.25	18.0	3	50
336L-1260	1.26	18.0	3	50
336L-1270	1.27	18.0	3	50
336L-1280	1.28	18.0	3	50
336L-1290	1.29	18.0	3	50
336L-1300	1.30	18.0	3	50
336L-1310	1.31	18.0	3	50
336L-1320	1.32	18.0	3	50
336L-1330	1.33	18.0	3	50
336L-1340	1.34	18.0	3	50
336L-1350	1.35	18.0	3	50
336L-1360	1.36	18.0	3	50
336L-1370	1.37	18.0	3	50
336L-1380	1.38	18.0	3	50
336L-1390	1.39	18.0	3	50
336L-1400	1.40	18.0	3	50
336L-1410	1.41	18.0	3	50
336L-1420	1.42	18.0	3	50
336L-1430	1.43	18.0	3	50
336L-1440	1.44	18.0	3	50
336L-1450	1.45	18.0	3	50
336L-1460	1.46	18.0	3	50
336L-1470	1.47	18.0	3	50
336L-1480	1.48	18.0	3	50
336L-1490	1.49	18.0	3	50
336L-1500	1.50	18.0	3	50

單位: (mm)

商品号 EDP NO.	直径 D1	刃长 H	柄径 D	全长 L
336L-1510	1.51	18.0	3	50
336L-1520	1.52	18.0	3	50
336L-1530	1.53	18.0	3	50
336L-1540	1.54	18.0	3	50
336L-1550	1.55	18.0	3	50
336L-1560	1.56	18.0	3	50
336L-1570	1.57	18.0	3	50
336L-1580	1.58	18.0	3	50
336L-1590	1.59	18.0	3	50
336L-1600	1.60	18.0	3	50
336L-1610	1.61	18.0	3	50
336L-1620	1.62	18.0	3	50
336L-1630	1.63	18.0	3	50
336L-1640	1.64	18.0	3	50
336L-1650	1.65	18.0	3	50
336L-1660	1.66	18.0	3	50
336L-1670	1.67	18.0	3	50
336L-1680	1.68	18.0	3	50
336L-1690	1.69	18.0	3	50
336L-1700	1.70	18.0	3	50
336L-1710	1.71	18.0	3	50
336L-1720	1.72	18.0	3	50
336L-1730	1.73	18.0	3	50
336L-1740	1.74	18.0	3	50
336L-1750	1.75	18.0	3	50
336L-1760	1.76	18.0	3	50
336L-1770	1.77	18.0	3	50
336L-1780	1.78	18.0	3	50
336L-1790	1.79	18.0	3	50
336L-1800	1.80	18.0	3	50
336L-1810	1.81	18.0	3	50
336L-1820	1.82	18.0	3	50
336L-1830	1.83	18.0	3	50
336L-1840	1.84	18.0	3	50
336L-1850	1.85	18.0	3	50
336L-1860	1.86	18.0	3	50
336L-1870	1.87	18.0	3	50
336L-1880	1.88	18.0	3	50
336L-1890	1.89	18.0	3	50
336L-1900	1.90	18.0	3	50
336L-1910	1.91	18.0	3	50
336L-1920	1.92	18.0	3	50
336L-1930	1.93	18.0	3	50
336L-1940	1.94	18.0	3	50
336L-1950	1.95	18.0	3	50
336L-1960	1.96	18.0	3	50
336L-1970	1.97	18.0	3	50
336L-1980	1.98	18.0	3	50
336L-1990	1.99	18.0	3	50
336L-2000	2.00	18.0	3	50
336L-2010	2.01	25.0	3	60

單位: (mm)

商品号 EDP NO.	直径 D1	刃长 H	柄径 D	全长 L
336L-2020	2.02	25.0	3	60
336L-2030	2.03	25.0	3	60
336L-2040	2.04	25.0	3	60
336L-2050	2.05	25.0	3	60
336L-2060	2.06	25.0	3	60
336L-2070	2.07	25.0	3	60
336L-2080	2.08	25.0	3	60
336L-2090	2.09	25.0	3	60
336L-2100	2.10	25.0	3	60
336L-2110	2.11	25.0	3	60
336L-2120	2.12	25.0	3	60
336L-2130	2.13	25.0	3	60
336L-2140	2.14	25.0	3	60
336L-2150	2.15	25.0	3	60
336L-2160	2.16	25.0	3	60
336L-2170	2.17	25.0	3	60
336L-2180	2.18	25.0	3	60
336L-2190	2.19	25.0	3	60
336L-2200	2.20	25.0	3	60
336L-2210	2.21	25.0	3	60
336L-2220	2.22	25.0	3	60
336L-2230	2.23	25.0	3	60
336L-2240	2.24	25.0	3	60
336L-2250	2.25	25.0	3	60
336L-2260	2.26	25.0	3	60
336L-2270	2.27	25.0	3	60
336L-2280	2.28	25.0	3	60
336L-2290	2.29	25.0	3	60
336L-2300	2.30	25.0	3	60
336L-2310	2.31	25.0	3	60
336L-2320	2.32	25.0	3	60
336L-2330	2.33	25.0	3	60
336L-2340	2.34	25.0	3	60
336L-2350	2.35	25.0	3	60
336L-2360	2.36	25.0	3	60
336L-2370	2.37	25.0	3	60
336L-2380	2.38	25.0	3	60
336L-2390	2.39	25.0	3	60
336L-2400	2.40	25.0	3	60
336L-2410	2.41	25.0	3	60
336L-2420	2.42	25.0	3	60
336L-2430	2.43	25.0	3	60
336L-2440	2.44	25.0	3	60
336L-2450	2.45	25.0	3	60
336L-2460	2.46	25.0	3	60
336L-2470	2.47	25.0	3	60
336L-2480	2.48	25.0	3	60
336L-2490	2.49	25.0	3	60
336L-2500	2.50	25.0	3	60
336L-2510	2.51	25.0	3	60
336L-2520	2.52	25.0	3	60

單位: (mm)

商品号 EDP NO.	直径 D1	刃长 H	柄径 D	全长 L
336L-2530	2.53	25.0	3	60
336L-2540	2.54	25.0	3	60
336L-2550	2.55	25.0	3	60
336L-2560	2.56	25.0	3	60
336L-2570	2.57	25.0	3	60
336L-2580	2.58	25.0	3	60
336L-2590	2.59	25.0	3	60
336L-2600	2.60	25.0	3	60
336L-2610	2.61	25.0	3	60
336L-2620	2.62	25.0	3	60
336L-2630	2.63	25.0	3	60
336L-2640	2.64	25.0	3	60
336L-2650	2.65	25.0	3	60
336L-2660	2.66	25.0	3	60
336L-2670	2.67	25.0	3	60
336L-2680	2.68	25.0	3	60
336L-2690	2.69	25.0	3	60
336L-2700	2.70	25.0	3	60
336L-2710	2.71	25.0	3	60
336L-2720	2.72	25.0	3	60
336L-2730	2.73	25.0	3	60
336L-2740	2.74	25.0	3	60
336L-2750	2.75	25.0	3	60
336L-2760	2.76	25.0	3	60
336L-2770	2.77	25.0	3	60
336L-2780	2.78	25.0	3	60
336L-2790	2.79	25.0	3	60
336L-2800	2.80	25.0	3	60
336L-2810	2.81	25.0	3	60
336L-2820	2.82	25.0	3	60
336L-2830	2.83	25.0	3	60
336L-2840	2.84	25.0	3	60
336L-2850	2.85	25.0	3	60
336L-2860	2.86	25.0	3	60
336L-2870	2.87	25.0	3	60
336L-2880	2.88	25.0	3	60
336L-2890	2.89	25.0	3	60
336L-2900	2.90	25.0	3	60
336L-2910	2.91	25.0	3	60
336L-2920	2.92	25.0	3	60
336L-2930	2.93	25.0	3	60
336L-2940	2.94	25.0	3	60
336L-2950	2.95	25.0	3	60
336L-2960	2.96	25.0	3	60
336L-2970	2.97	25.0	3	60
336L-2980	2.98	25.0	3	60
336L-2990	2.99	25.0	3	60
336L-3000	3.00	25.0	3	60