

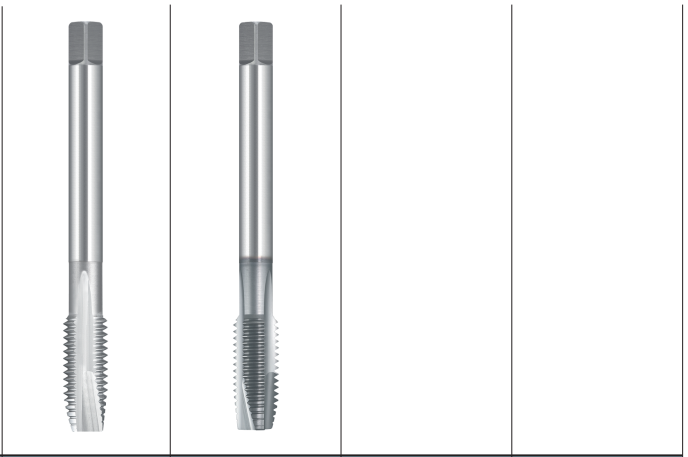

## A21系列 - 通孔 - 中强钢 - 螺尖丝锥

### M 公制粗牙螺纹

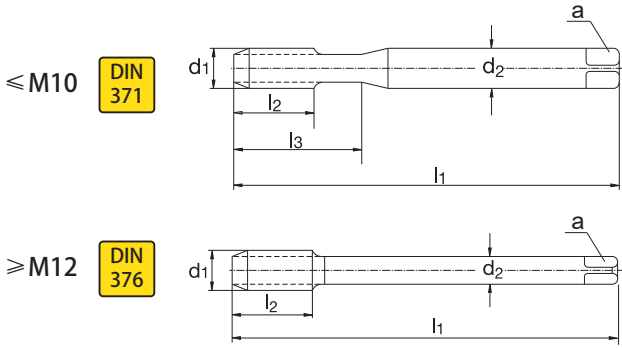

加工特性及说明		系列号	A2100	A2160							
<p>A21系列为直槽螺尖丝锥，可加工HRC38以下的低、中强度钢及硬度较高的长屑有色金属的通孔螺纹。</p> <p>A2100为无涂层及热处理经济型，价格优惠，种类齐全；</p> <p>A2160为带TiAlN多层涂层的标准型，硬度，耐磨性及耐热性显著提高。尤其适合于干切削和润滑条件不佳时，如水平加工，丝锥寿命大幅提高。</p> <p>● = 标准在库                      订货号=系列号.规格号，如 A2100.006                      切削参数Vc详见第1页</p>		底孔形状									
		螺纹深度	3xD	3xD							
		加工材料	P22 P38	P22 P38							
		螺旋角	0	0							
		槽型	直槽螺尖	直槽螺尖							
		涂层/处理		TiAlN							
		材质	HSSE	HSSE							
		切削锥型	B	B							
		公差	6H	6H							
		其它特性	经济型	标准型							
应用等级											
d	P mm	l <sub>1</sub>	l <sub>2</sub>	l <sub>3</sub>	d <sub>2</sub>	a		规格号			
M 2	0.4	45	6	10	2.8	2.1	1.60	002	●	●	
M 2.5	0.45	50	9	14	2.8	2.1	2.05	0025	●	●	
M 3	0.5	56	10	18	3.5	2.7	2.50	003	●	●	
M 3.5	0.6	56	11	20	4	3	2.90	0035			
M 4	0.7	63	12	23	4.5	3.4	3.30	004	●	●	
M 5	0.8	70	14	25	6	4.9	4.20	005	●	●	
M 6	1.0	80	17	30	6	4.9	5.00	006	●	●	
M 8	1.25	90	18	35	8	6.2	6.80	008	●	●	
M 10	1.5	100	20	39	10	8	8.50	010	●	●	
M 12	1.75	110	22		9	7	10.20	012	●	●	
M 14	2.0	110	25		11	9	12.00	014	●	●	
M 16	2.0	110	25		12	9	14.00	016	●	●	
M 18	2.5	125	32		14	11	15.50	018	●	●	
M 20	2.5	140	32		16	12	17.50	020	●	●	
M 22	2.5	140	32		18	14.5	19.50	022	●	●	
M 24	3.0	160	36		18	14.5	21.00	024	●	●	
M 27	3.0	160	36		20	16	24.00	027	●	●	
M 30	3.5	180	40		22	18	26.50	030	●	●	
M 36	4	200	45		28	22	32.00	036	●	●	

材料编号	P22	P38	P42	M	K	N1	N2	S1	S2
种类	低强钢	中强钢	高强钢	不锈钢	铸铁	长屑铝铜	短屑铝铜	钛合金	低强镍合金
抗拉强度	<800N/mm <sup>2</sup>	<1200N/mm <sup>2</sup>	<1300N/mm <sup>2</sup>	<1200N/mm <sup>2</sup>		<800N/mm <sup>2</sup>		<1300N/mm <sup>2</sup>	<900N/mm <sup>2</sup>
硬度	<HRC22	<HRC38	<HRC42	<HRC38	<HB350	<HRC22	<HB300	<HRC42	<HRC28